

Big Blue® 300 Pro

Issued September 2011 • Index No. ED/5.21

**Diesel Engine-Driven
Welder/AC Generator** 

Quick Specs

Heavy Industrial Applications

Mechanical Contractors
Structural Steelwork
Fabrication
Maintenance
Repair
Rental
Construction

Processes

Stick (SMAW)
MIG (GMAW)
Flux-Cored (FCAW)
DC TIG (GTAW)
Air Carbon Arc (CAC-A)
Rated: 3/16-inch (4.8 mm) carbons,
Capable: 1/4-inch (6.4 mm) carbons
Air Plasma Cutting and Gouging with
optional Spectrum® models

Output Range DC Stick 20–410 A
DC TIG 20–410 A
FCAW/MIG 14–40 V

Generator Output Rated at 104° F (40° C)
12,000 Watts Peak
10,000 Watts Continuous

**Accu-Rated™ – Not Inflated
Generator Power**

The Power of Blue.®

The Professional Welder's Choice — designed with the professional in mind, the Big Blue 300 Pro is the best for ease of use, reliability and fuel economy.

Distributed By:



www.onesourcerental.com



CATERPILLAR C1.5
three-cylinder diesel.



Kubota V1505 four-cylinder diesel.



Mitsubishi S4L2 four-cylinder diesel.

Heavy-duty low-speed industrial engines are designed to operate over 10,000 hours before the first basic overhaul. Backed by worldwide support and service.

Meter maintenance displays

- Fuel gauge
- Hour meter function
- Oil change interval
- High coolant temperature and low oil pressure shutdowns
- Low fuel shutdown — engine shuts down before system runs out of fuel, making restarts easy.

Quiet operation. Improves work site communication.

Thermal overload protection prevents machine damage if the duty cycle is exceeded or airflow is blocked.

Optional Stainless Steel Appearance Package provides additional exterior protection to withstand corrosive environments.

Superior arc performance

- Four preset DIG settings (Stick)
- Hot Start™ (Stick)
- Lift-Arc™ TIG with Auto-Stop™ and Crater-out
- MIG/FCAW arc performance

Simple-to-set controls require no elaborate procedure — just select process and weld!

Auto Remote Sense™ (ARS) detects if a remote control is plugged into the 14-pin receptacle and eliminates confusion of a remote/panel switch.

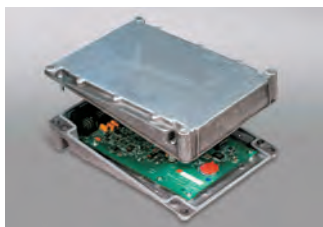

The Vault — ultimate control board reliability. See page 4.



Standard features include: digital preset weld meters, output contactor control, and automatic idle.



Welder/generator is warranted by Miller for 3 years, parts and labor.
Engine is warranted separately by engine manufacturer.

MADE IN USA
APPLETON, WI 



Miller Electric Mfg. Co.
An Illinois Tool Works Company
1635 West Spencer Street
Appleton, WI 54914 USA

Equipment Sales US and Canada
Phone: 866-931-9730
FAX: 800-637-2315
International Phone: 920-735-4554
International FAX: 920-735-4125

Web Site
www.MillerWelds.com



Specifications (Subject to change without notice.)



Weld Mode	Weld Output Range	Weld Output Rated at 104° F (40° C)	Max. Open-Circuit Voltage	Generator Power Output Rated at 104° F (40° C)	Sound Levels at Rated Output, 23 ft. (7 m)	Dimensions	Weight (without fuel)*
CC/DC	20–410 A	400 A, 21 VDC, 30% Duty Cycle 300 A, 32 VDC, 60% Duty Cycle	65	Peak: 12,000 watts Continuous: 10,000 watts Single-phase, 83/42 A, 120/240 VAC, 60 Hz	72.2 dB (97 Lwa)	H: 32 in. (813 mm) W: 26.25 in. (667 mm) D: 56 in. (1422 mm)	Weight (without fuel)* CAT: Net: 1100 lb. (499 kg) Ship: 1150 lb. (522 kg) Kubota: Net: 1040 lb. (472 kg) Ship: 1090 lb. (494 kg) Mitsubishi: Net: 1083 lb. (491 kg) Ship: 1133 lb. (514 kg)
CV/DC	14–40 V						

*Additional 82 lb. (37 kg) when fuel tank is full.

Certified by Canadian Standards Association to both the Canadian and U.S. Standards. Meets NEMA and IEC output ratings.

Engine Specifications (Engines warranted separately by the engine manufacturer.)

Engine Brand	Features	HP	Type	Engine Speeds	Fuel Capacity	Oil Capacity	Coolant Capacity	Automatic Engine Shutdown
CATERPILLAR C1.5	EPA Tier 4i compliant, indirect-injected, liquid-cooled engine. Right-side service access with intervals of 250 hrs for oil and filters.	21.7	3-cylinder, industrial liquid-cooled, diesel	1850 RPM weld (1500 RPM idle)	11.5 gal (43.5 L)	6 qt (5.7 L)	6 qt (5.7 L)	Low Oil Pressure, High Coolant Temperature, Low Fuel Level
Kubota V1505	EPA Tier 4i compliant, indirect-injected, liquid-cooled engine. Right-side service access with intervals of 250 hrs for oil and filters. 120 V block heater is standard.	20.2	4-cylinder, industrial liquid-cooled, diesel	1850 RPM weld	11.5 gal (43.5 L)	6 qt (5.7 L)	6 qt (5.7 L)	
Mitsubishi S4L2	EPA Tier 4i compliant, indirect-injected, liquid-cooled engine. Right-side service access with intervals of 500 hrs for oil and filters.	24.4	4-cylinder, industrial liquid-cooled, diesel	1850 RPM weld (1500 RPM idle)	11.5 gal (43.5 L)	6.3 qt (6 L)	10 qt (9.5 L)	

Performance Data

STICK MODE V/A CURVE – MAX DIG

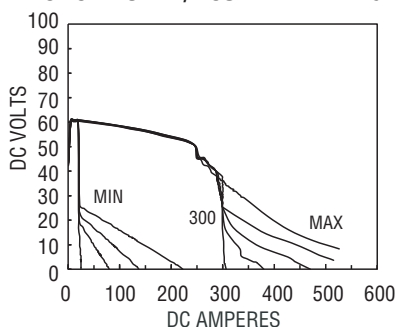

GENERATOR POWER CURVE

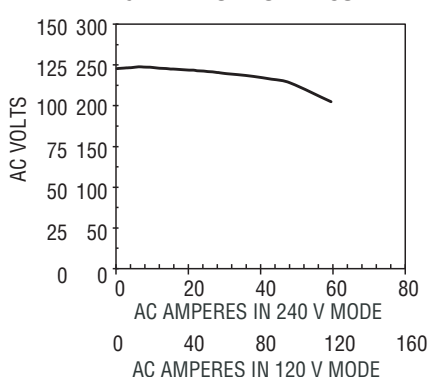

DC TIG MODE V/A CURVE

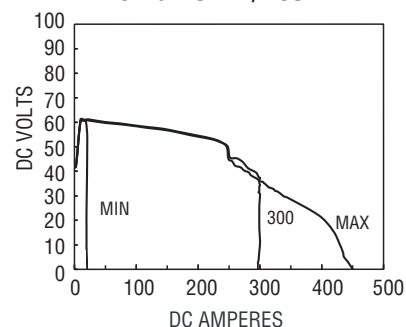

MIG MODE V/A CURVE

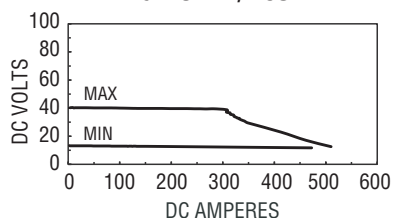

FUEL CONSUMPTION CURVE

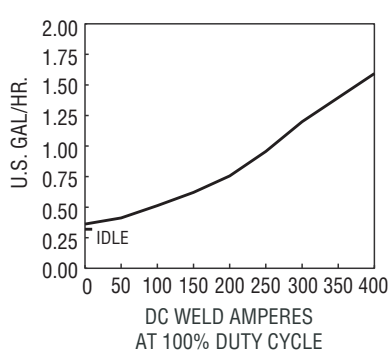

SIMULTANEOUS WELDING AND POWER

Weld Amperes	Total Power Available (Watts)	120 V	240 V
225	3000	25	12.5
175	5000	41.6	20.8
125	5900	49.2	24.6
75	7300	60.8	30.4
25	10,000	83.5	41.7

Distributed By:

One Source Equipment Rentals

www.onesourcerental.com



Function Guide

1. **Self-Calibrating Digital Weld Meters with Fault Code Indication** display preset or actual weld parameters.
2. **Four Preset DIG Settings** offer the best arc characteristics for different electrodes and joint designs. The amount of DIG determines how much amperage (heat) varies with Stick arc length. The combined process switch along with preset DIG settings make the Big Blue® 300 Pro easy to set without the complication of multiple switches.
3. **Hot Start™** provides positive Stick electrode starts for easy starts on all electrodes types and it also works great for bead tie-ins.
4. **Great MIG/FCAW Performance and Arc Starts** make the Big Blue® 300 Pro's arc best in its class. Easy to run all wires from .023-inch solid wires to large diameter 5/64-inch flux-cored wires.
5. **Lift-Arc™ TIG with Auto-Stop™ and Crater-out**
6. **Standard 14-Pin Receptacle** for simple connection of remote controls and wire feeders. Includes **Auto Remote Sense™** which automatically switches from panel to remote amperage/voltage (A/V) control with remote connected. Eliminates confusion of a panel/remote switch.
7. **Weatherproof Lexan® Nameplate** is super durable and resists cracking and fading. Color coded for ease of operation.
8. **Meter Maintenance Displays** show fuel level, engine hours, oil change interval and hi temp/low pressure/low fuel shutdown information.
Low Fuel Shutdown shuts engine off prior to running out of fuel to prevent loss of fuel in the system, and make restarts easy. Display will read noFUEL. Turn the machine off, add fuel, and restart.
9. **Glow Plugs** assist in cold weather starting.
10. **Engine Control Switch** is used to start the engine and then select between Auto Idle and High Speed Lock.
11. **Amperage/Voltage Adjust Control**
12. **120 VAC and 240 VAC Receptacles with Circuit Breakers** (optional 120 VAC GFCI receptacles available).
Note: For matching plug, order #119 172.
13. **Weld Output Terminals**

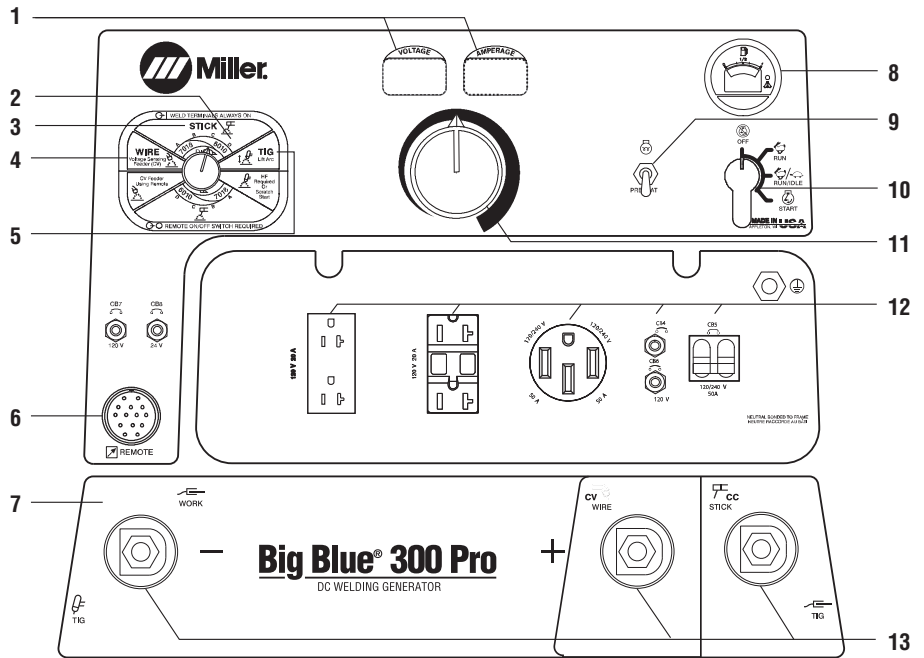

ARC START with Lift-Arc™

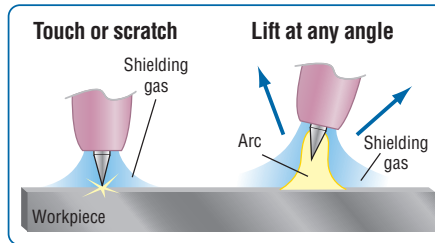

- Reduces or eliminates sticking
- Reduces or eliminates electrode/work contamination
- Low open-circuit voltage

ARC END with Auto-Stop™

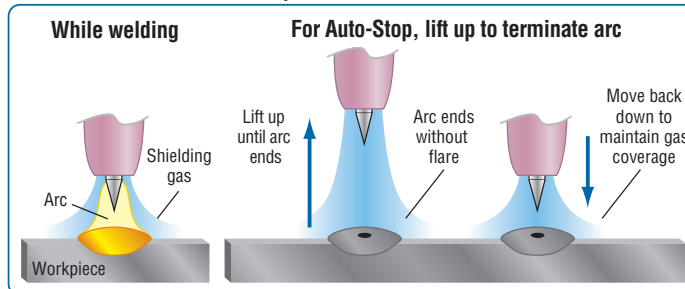

- Eliminates need for a remote control
- Maintains shielding gas coverage
- Eliminates tungsten and workpiece contamination
- Eliminates unwanted arc strikes outside the weld area

ARC END with Crater-out

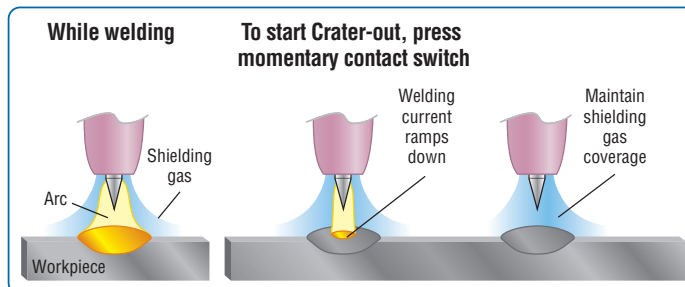

- Maintains shielding gas coverage
- Eliminates tungsten and workpiece contamination
- Crater-out time allows for addition of filler
- Eliminates unwanted arc strikes outside the weld area

Distributed By:

One Source Equipment Rentals

www.onesourcerental.com



What Makes Miller® Industrial Engine Drives So **[TOUGH]**?

Superior Circuit Board Design

Miller's critical circuit boards are engineered to carry *low power* and *low heat* to reduce thermal stress and minimize expansion and contraction. In contrast, our competitor's boards carry *high power* and *high heat*, making them more vulnerable to failure.



"The Vault" Makes Upgrading to Miller® CC/CV Units Worry-Free

Concerns with circuit board reliability have resulted in some operators steering clear of CC/CV welder/generators — even though they offer a superior arc and multiple welding processes. Miller circuit board reliability isn't a concern since all Big Blue multiprocess industrial engine drives feature the Vault.

Created out of two aluminum halves sealed with silicone, as well as watertight harness connections, the Vault provides a clean circuit board environment, protecting the electronics — and controlling output — in heavy industrial applications. No other competitor protects their electronics with a sealed vault, leaving critical circuit boards exposed to harsh elements that can disrupt the machine's electronics, and therefore, its operation.



"The Big Blue® 300 Pro worked year 'round and never caused any problems. We were amazed at the cold-weather starting. A machine that doesn't run means we have to work overtime... secondly, you don't want to have a crew standing around at \$200 an hour while someone tries to start the machine."

Edward McNaughton, Nordcap Steel Docks

Rigorous Testing for Tough, Real-World Conditions

To prove our machines go to the limit, Miller industrial engine drives are put to the test in very extreme environmental conditions.

- **Airborne dust and sand.**

Critical components are exposed to abusive airborne particles in a special testing chamber for weeks, helping make sure they'll operate while facing extreme levels of dirt, dust or sand on the job site.

- **Humidity and corrosion.**

Inside our Houston testing room, critical components are subjected to extended moisture and corrosive salt exposure to ensure they'll run even when exposed to humid climates, corrosive coastal environments, and driving rain.

- **Temperature extremes.** Miller industrial engine drives are tested to ensure performance in scorching heat. All Miller engine-driven machines are weld rated at 104 degrees Fahrenheit, but actual tests are conducted up to 122 degrees Fahrenheit to assure peak performance.

- **Jobsite/over-the-road abuse.** Miller industrial engine drives are shaken for hours on transportation bed simulators, subjected to severe vibration, and test-dropped and jerked to ensure they'll withstand the stresses that can shut down competitive machines.

- **Continuous operation.** Miller industrial engine drives run day and night, in all weather conditions, to assure they'll perform without interruption in the field.



Why Industrial Engine Drive Customers Choose Miller

The ultimate test of Miller reliability is how it performs in the field. The quote on the left provides a glimpse of how Miller industrial engine drives perform for customers. Read the full stories, and many others demonstrating our superior reliability, at MillerWelds.com.

Distributed By:

One Source Equipment Rentals

www.onesourcerental.com





Female Receptacle



Adapter Cord, Full KVA #300 517 Field NEMA 14-50P to NEMA 6-50R. Adapts engine drive 120/240 V plug to common Millermatic® and Spectrum® 240 V plug.



Full KVA Plug Kit #119 172 Field 120/240 VAC, 50 A plug (NEMA 14-50P) to fit full KVA receptacle.

Cold Weather Starting Aid

#195 056 Field. For CAT
#300 664 Field. For Mitsubishi 120 V Block Heater.

Note: All models come standard with preheaters (glow plugs).

Engine Filter Kits

#246 987 Field. For CAT
#253 901 Field. For Kubota
#252 782 Field. For Mitsubishi
Includes all filters required for proper engine maintenance. Oil filter, primary and secondary fuel filter, and primary air filter.

Spark Arrestor (Muffler) Kit

#195 291 Field. For CAT
#300 585 Field. For Mitsubishi
Prevents particles from leaving the muffler that could potentially start a fire. Mandatory when operating on California grasslands, brush, or forest-covered land, and all national forests. For other areas, check your state and local laws. Meets U.S. Forest Service Standard 5100-1B.



FA-1D Lockable Flame Arrestor Fuel Cap #043 947
Fuel cap can be padlocked to prevent vandalism. A built-in flame arrestor prevents flames or sparks from entering the fuel tank.

Chalwyn Safety Valve

#300 576 Field. For Mitsubishi
Shuts off air flow to the engine to prevent over-speed condition. Required on many petroleum jobsites, this valve provides both manual and automatic operation giving you two methods of operation to meet jobsite compliance standards.

Protective Cover #195 301 Field
Blue water-resistant cover with Miller logo resists stains and mildew, and protects the finish of your welder.

Distributed By:

Stick (SMAW) Welding

Weld Leads

2/0 Stick Cable Set, 50 ft. (15 m) #173 851
Consists of 50-foot (15 m) electrode cable with holder, and 50-foot (15 m) work cable with clamp. 350 A, 100% duty cycle.

2/0 Stick Cable Set, 100/50 ft. (30.5/15 m) #043 952

Consists of 100-foot (30.5 m) electrode cable with holder, and 50-foot (15 m) work cable with clamp. 300 A, 100% duty cycle.

Plasma Cutting



Spectrum 375 X-TREME and 625 X-TREME shown.

Spectrum® 375 X-TREME™ #907 529
See Lit. Index No. PC/9.2.

Spectrum® 625 X-TREME™ #907 531
See Lit. Index No. PC/9.6.

Spectrum® 875 #907 390-01-1
See Lit. Index No. PC/9.8.

The Spectrum 375 X-TREME and 625 X-TREME come complete with protective X-CASE™ (not shown).

MIG (GMAW) or Flux-Cored (FCAW)



SuitCase® X-TREME™ 8VS Wire Feeder #951 182

SuitCase® X-TREME™ 12VS Wire Feeder #951 184

Lightweight, voltage-sensing wire feeders include secondary contactor, gas valve and drive roll kit. See Lit. Index No. M/6.41.



SuitCase® 8RC Wire Feeder #951 186
SuitCase® 12RC Wire Feeder #951 188

Lightweight and flexible enough to run a variety of wires up to 5/64-inch diameter. Includes remote voltage control and drive roll kit. See Lit. Index No. M/6.5.

MIG (GMAW)/Flux-Cored (FCAW) Guns
Miller produces a complete line of dependable MIG guns. See Lit. Index Nos. AY/15.0, AY/16.0 and AY/17.0.



Spoolmatic® 30A Spool Gun #130 831
Air-cooled, 200-amp, 1-pound spool gun

for aluminum MIG. See Lit. Index No. M/1.73. Requires **WC-24 Control (#137 549)**.

XR™ Wire Feeders and Guns

Push-pull system designed to handle difficult-to-feed soft alloy wires such as aluminum. See Lit. Index No. M/1.7, M/1.71, and M/1.73.

TIG (GTAW) Welding



Dynasty® 200 Series #907 099 #907 099-01-1
For premium portable AC/DC

TIG arc quality. See Lit. Index No. AD/4.8.



HF-251 Series #042 388
HF-251D-1, 115 VAC
High-frequency arc starter and stabilizer. See Accessory Lit. Index No. AY/5.0.

Multiple Operator Welding

The XMT 350, CST 280 and Dynasty 200 power sources can be run off the machine's generator to provide two arcs with only one engine. There is no arc interaction under 180 amps.



XMT® 350 Series #907 161, #907 224, #907 366
See Lit. Index No. DC/18.83.



CST™ 280 #907 244, #907 244-01-1 #907 251, #907 251-01-1
See Lit. Index No. DC/29.55.

One Source Equipment Rentals

www.onesourcerental.com



Genuine Miller® Accessories (continued)

Remote Controls



Wireless Remote Foot Control #300 429
For remote current, voltage and contactor control. Receiver plugs directly into the 14-pin receptacle of Miller machine. 90-foot (27.4 m) operating range. Requires **Wireless Antenna Kit (#300 749)**.



Wireless Remote Hand Control #300 430
For remote current, voltage and contactor control. Receiver plugs directly into the 14-pin receptacle of Miller machine. 300-foot (91.4 m) operating range. Requires **Wireless Antenna Kit (#300 749)**.

Wireless Antenna Kit #300 749
Required for Pro Series engine drives. Optional on other compatible Miller products where improved reception is desired.

RFCS-14 HD Foot Control #194 744
Heavy-duty foot control for remote current, voltage and contactor control. Includes 20-foot (6 m) cord and 14-pin plug.

RHC-14 Hand Control #242 211 020
Miniature hand control for remote current, voltage and contactor control. Dimensions: 4 x 4 x 3.25 inches (102 x 102 x 82 mm). Includes 20-foot (6 m) cord and 14-pin plug.



RMS-14 On/Off Control #187 208
Momentary-contact switch for contactor control. Rubber-covered pushbutton dome switch ideal for repetitive on-off applications. Includes 26.5-foot (8 m) cord and 14-pin plug.



RCC-14 Remote Contactor and Current Control #151 086 14-pin plug
Rotary-motion fingertip control fastens to TIG torch using two Velcro® straps. Includes 28-foot (8.5 m) control cord.



PRHC-14 Hand Control #195 511
Complete current or voltage control brings 120 volts GFCI power to work area in a single cord. Housed in a durable, light aluminum case and includes 125-foot (38 m) cord with plugs.

Extension Cords for 14-Pin Remote Controls or 24 VAC Wire Feeders

- #242 208 025** 25 ft. (7.6 m)
- #242 208 050** 50 ft. (15.2 m)
- #242 208 080** 80 ft. (24.4 m)

Trailers and Hitches (Note: Trailers are shipped unassembled.)



Shown with ball hitch, fenders and lights.

HWY-224 Trailer #043 805 For highway use.

OFR-224 Trailer #043 802 For off-road use.
A 2650-pound (1202 kg) capacity trailer. Welded steel tubing frame, heavy-duty axle with roller bearing hubs and leaf-spring suspension. Includes jack stand, 2-inch (50 mm) ball hitch. *HWY-224 also includes fenders and lights.*

Cable Tree #043 826
Provides an area to conveniently wrap weld cables and extension cords.



Dual Hitch #300 831
2-inch (50 mm) ball hitch and 3-inch (76 mm) lunette eye in one reversible assembly.

Mounting Specifications

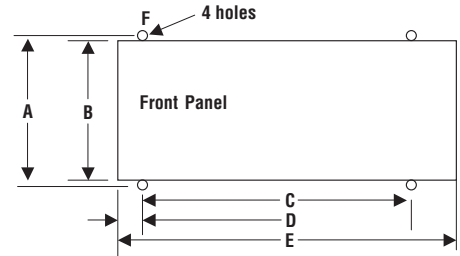

- A.** 27.75 in. (705 mm)
- B.** 26.25 in. (667 mm)
- C.** 52 in. (1321 mm)
- D.** 2 in. (51 mm)
- E.** 56 in. (1422 mm)
- F.** .562 in. (14 mm) dia.

Height: 32 in. (813 mm)
Width: 26.25 in. (667 mm)
Depth: 56 in. (1422 mm)

Trailer Specifications (Subject to change without notice.)

Model	Gross Axle Weight Rating	Gross Vehicle Weight Rating	Net Payload	Height of Bed	Road Clearance	Track (Center to center of tires)	Standard Tires (Standard rating or P-size rating)	Dimensions	Net Weight
HWY-224 OFR-224	3500 lb. (1588 kg)	2960 lb. (1343 kg)	2650 lb. (1202 kg)	18.5 in. (470 mm)	7.5 in. (191 mm)	52 in. (1321 mm)	B78-13	Length: 105 in. (2667 mm) Width: HWY-59.5 in. (1511 mm)* OFR-58.437 in. (1484 mm)	320 lb. (145 kg)

*Width at outside of fenders.

Distributed By:

One Source Equipment Rentals

www.onesourcerental.com

Typical Installations

Electrode Hot



Stick (SMAW) Basic Equipment

PRHC-14 #195 511
 Wireless Remote Hand Control #300 430
 Wireless Antenna Kit #300 749

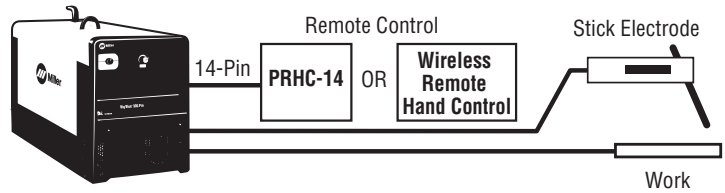

Flux-Cored/MIG (FC) Basic Equipment

SuitCase® X-TREME™ 8VS #951 182
 SuitCase® X-TREME™ 12VS #951 184

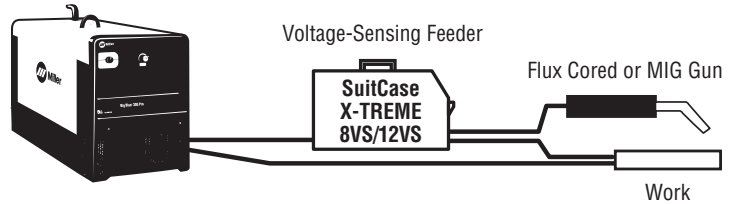

Lift-Arc™ TIG (GTAW) Basic Equipment

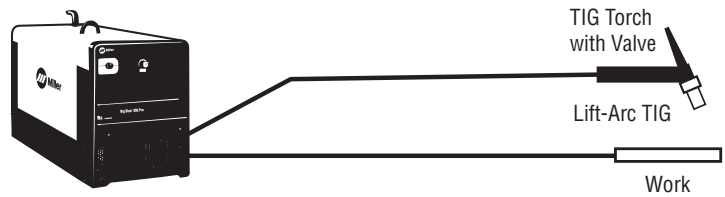

Remote On/Off Required



Stick (SMAW) Basic Equipment

RHC-14 #242 211 020
 Wireless Remote Hand Control #300 430
 Wireless Antenna Kit #300 749

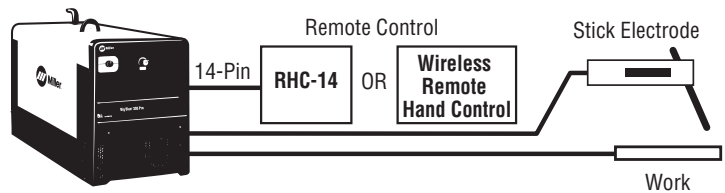

Flux-Cored/MIG (FC) Basic Equipment

SuitCase® 8RC #951 186
 SuitCase® 12RC #951 188

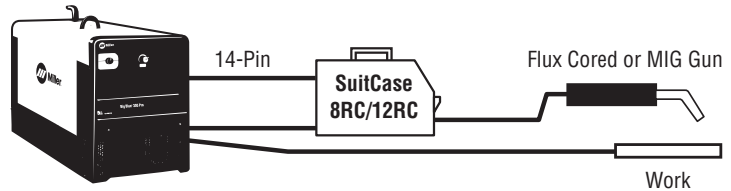

Aluminum MIG (GMAW) Basic Equipment

Spoolmatic® 30A #130 831
 WC-24 #137 549

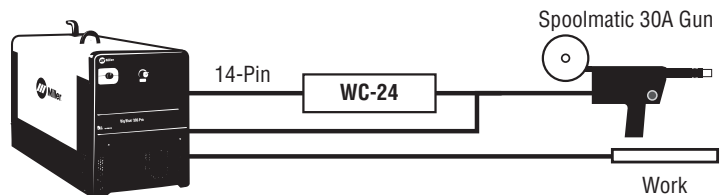

TIG (GTAW) Basic Equipment

HF-251D-1 #042 388*
 Dynasty® 200 SD #907 099
 Dynasty® 200 DX #907 099-01-1
 *TIG power cable adapter required

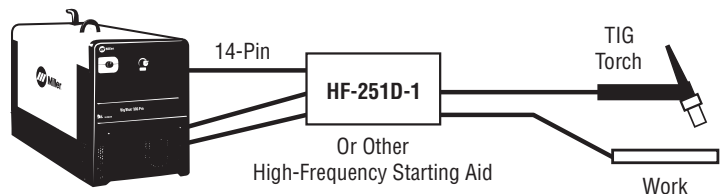

Distributed By:

One Source Equipment Rentals

www.onesourcerental.com



Ordering Information

Equipment and Options	Stock No.	Description	Qty.	Price
Big Blue® 300 Pro	#907 144	CAT CC/CV with Auto-Idle		
	#907 144-01-1	CAT CC/CV with Auto-Idle and 120 V Block Heater		
	#907 144-02-1	CAT CC/CV with Auto-Idle, 120 V Block Heater and Stainless Steel Package		
	#907 521	Kubota CC/CV with 120 V Block Heater		
	#907 472	Mitsubishi CC/CV with Auto-Idle		
	#907 472-01-1	Mitsubishi CC/CV with Auto-Idle and 120 V Block Heater		
Field Accessories				
Adapter Cord, Full KVA	#300 158	Field		
Full KVA Plug Kit	#119 172	Field		
Cold Weather Starting Aid (120 V block heater)	#195 056	Field. For CAT		
	#300 664	Field. For Mitsubishi		
Engine Filter Kit	#246 987	Field. For CAT, includes air, oil and fuel filters		
	#253 901	Field. For Kubota, includes air, oil and fuel filters		
	#252 782	Field. For Mitsubishi, includes air, oil and fuel filters		
Spark Arrestor (Muffler) Kit	#195 291	Field. For CAT		
	#300 585	Field. For Mitsubishi		
FA-1D Lockable Flame Arrestor Fuel Cap	#043 947	Field		
Chalwyn Safety Valve	#300 576	Field. For Mitsubishi		
Protective Cover	#195 301	Field		
Stick Welding Leads		See page 5		
Plasma Cutting				
Spectrum® 375 X-TREME™	#907 529	Includes X-CASE™. See Lit. Index No. PC/9.2		
Spectrum® 625 X-TREME™	#907 531	Includes X-CASE™. See Lit. Index No. PC/9.6		
Spectrum® 875	#907 390-01-1	See Lit. Index No. PC/9.8		
MIG/Flux-Cored Welding				
SuitCase® X-TREME™ 8VS	#951 182	See Lit. Index No. M/6.41		
SuitCase® X-TREME™ 12VS	#951 184	See Lit. Index No. M/6.41		
SuitCase® 8RC	#951 186	See Lit. Index No. M/6.5		
SuitCase® 12RC	#951 188	See Lit. Index No. M/6.5		
MIG (GMAW) and Flux-Cored (FCAW) Guns		See Lit. Index Nos. AY/15.0, AY/16.0 and AY/17.0		
Spoolmatic® 30A Spool Gun	#130 831	Requires WC-24 Control. See Lit. Index No. M/1.73		
WC-24 Control	#137 549	See Lit. Index No. M/1.5		
XR™ Wire Feeder Control and Guns		See Lit. Index No. M/1.7, M/1.71, and M/1.73		
TIG Welding				
Dynasty® 200 SD	#907 099	Basic controls for AC/DC TIG/Stick, 120–460 VAC. See Lit. Index No. AD/4.8		
Dynasty® 200 DX	#907 099-01-1	Full feature controls for AC/DC TIG/Stick, 120–460 VAC. See Lit. Index No. AD/4.8		
HF-251D-1	#042 388	115 VAC. See Lit. Index No. AY/5.0		
Multiple Operator Welding				
XMT® 350 Series	#907 161	CC/CV model w/Dinse-style connectors. See Lit. Index No. DC/18.83		
	#907 224	VS model w/Tweco®-style connectors. See Lit. Index No. DC/18.83		
	#907 366	MPa model w/Dinse-style connectors. See Lit. Index No. DC/18.83		
CST™ 280 CC/DC	#907 244	220-230/460–575 VAC w/Dinse-style connectors. See Lit. Index No. DC/29.55		
	#907 244-01-1	220-230/460–575 VAC w/Tweco®-style connectors. See Lit. Index No. DC/29.55		
	#907 251	208-230/400–460 VAC w/Dinse-style connectors. See Lit. Index No. DC/29.55		
	#907 251-01-1	208-230/400–460 VAC w/Tweco®-style connectors. See Lit. Index No. DC/29.55		
Remote Controls and Switches		See page 6		
Trailers and Hitches				
HWY-224 Trailer	#043 805	Trailer with lights, fenders and 2-inch (50 mm) ball hitch. For highway use		
OFR-224 Trailer	#043 802	Trailer with 2-inch (50 mm) ball hitch. For off-road use		
Cable Tree	#043 826	Trailer-mounted cable holder for HWY-224 or OFR-224		
Dual Hitch	#300 831	Combination 2-inch (50 mm) ball hitch and 3-inch (76 mm) lunette eye in one reversible assembly. For HWY-224 or OFR-224		

Date:

Total Quoted Price:



Distributed by:



www.onesourcerental.com