

Magnum Mobile Generator – MMG480 Specifications

ENGINE

- John Deere® RG6135HFG495 - turbocharged, diesel engine
 - Standby - 634 hp @ 1800 rpm
 - Prime – 571 hp @ 1800 rpm
 - 6 cylinder
 - 13.5 L displacement
 - Interim Tier IV approved
- Steel, single wall fuel tank
 - 616 gal. capacity
 - 20 hr. run time – full load
 - Fuel tank built into skid of generator set
- Fuel consumption at prime:
 - 100% - 28.4 gph (107.6 Lph)
 - 75% - 20.8 gph (78.7 Lph)
 - 50% - 14.2 gph (53.7 Lph)
- Cooling system capable of operating at 120°F ambient
- Low coolant shutdown
- Radiator and oil drains plumbed to exterior
- Rubber vibration dampers isolate engine/generator from frame
- In-line engine block heater
- Disposable air filter - paper element
- Air filter restriction indicator mounted on control panel
- 60 Hz engine/generator
- Electronic isochronous governing

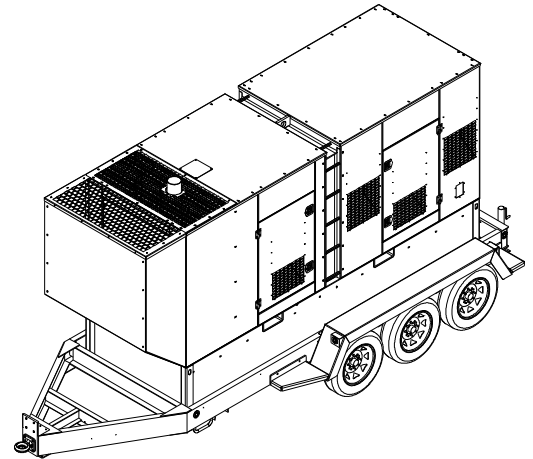

Distributed By:



www.onesourcerental.com

GENERATOR

- Marathon Electric®
 - Brushless
 - PMG Generator - critical grade power quality
 - 4 pole
 - Class H insulation
- Voltage regulation +/- 1% with Marathon PM300 Voltage Regulator

SYSTEM OUTPUT

- Link / Reconnect Board:
 - Three phase – 120 / 208V Low Wye
 - Three phase – 277 / 480V High Wye
- 419 kW / 524 kVA – standby, three phase
- 379 kW / 474 kVA – prime, three phase

SYSTEM CONTROLS

- Power Zone™ controller and display
 - Backlit, 800 x 480 pixel resolution color display
 - -40°F to 185°F operating temperature range
 - Automatic coarse voltage adjustment
 - Integrated fine voltage adjustment
 - PLC functionality
- Push buttons for easy operation
 - Manual or Auto Start
 - Engine Start
 - Engine Stop/Reset
 - Alarm Mute
 - Operator Screens
 - ◆ Home
 - ◆ Engine
 - ◆ Generator
 - ◆ Voltage Adjust
 - Scrolling Arrows for Diagnostic Information
 - ◆ Engine diagnostic display
 - Oil pressure
 - Engine temperature
 - Fuel level
 - Battery
 - Aftertreatment inlet/outlet temperature
 - Ash/soot levels
 - ◆ Generator diagnostic display
 - System kW output display
 - Line output & frequency display
 - ◆ Alarms
 - Warning
 - Shutdown
 - Electrical Trip
 - Engine
 - ◆ Alarm list – warnings / shutdowns 250 event history log – date/time stamp
 - Fuel level: warning – 15%; shutdown – 5%
 - Overspeed protection: shutdown – 115%
 - Oil pressure: warning – 25 psi; shutdown – 20 psi
 - Coolant temperature: warning – 220°F; shutdown – 230°F
 - Battery voltage: over – 15VDC; under – 11VDC
 - Generator over voltage: warning – 110%; electrical trip – 111%
 - Generator under voltage: warning – 87%; electrical trip – 86%
 - Generator over frequency: warning – 105%; electrical trip – 110%
 - Generator under frequency: warning – 95%; electrical trip – 90%
 -
 - ◆ Inputs/Outputs
 - ◆ Auto Schedule
 - ◆ Status
 - Configuration of controller, firmware and connections

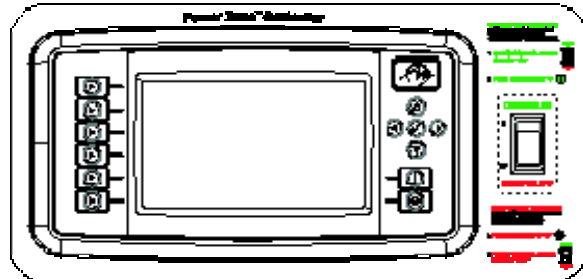



ELECTRICAL CONTROLS

- Remote start / stop contacts located next to lug box
- Lockable control box door with diagnostics window
- Lockable lug box with safety switch
 - Trips main breaker when lug door is opened
 - Disables voltage regulator

- Cable entry guides to the lug box
 - Restricts access of foreign objects
- Output ground connection lug inside lug box
- 1600A main breaker with shunt trip
- Convenience receptacles with individual breakers (restricted use in high wye mode)
 - (2) 120V 20 Amp GFCI duplex outlets (Nema 5-20R type)
 - (3) 125 / 250V 50 Amp, 3 pole, 4 wire twistlock (Non-Nema 6369)
 - Buck Transformer kit – Provides 120V at GFCI outlets when in 277/480V
- Panel mounted rheostat for voltage adjustment - +/- 10%
- (2) 1000 CCA wet cell batteries
 - Battery disconnect switch
 - 2A trickle battery charger

ENCLOSURE

- Aluminum, sound attenuated enclosure
 - UV & fade resistant, high temperature cured, white polyester powder paint
 - Insulated and baffled; 120 % containment
 - 68 dB(A) at 23 feet – prime power
- Fully lockable enclosure including doors and fuel fill
- Stainless steel hinges on doors
- Emergency stop switch located on outside of enclosure
- Central lifting point
- Multi-lingual operating/safety decals
- Document holder with operating manual including AC/DC wiring diagrams

TRAILER

- DOT approved tail, side, brake, and directional lights
 - Recessed rear lights
- Transportation tie downs
- Safety chains with spring loaded safety hooks
- 3” lunette ring hitch
- (3) 8000 lb. axles with electric brakes
- 15000 lb. tongue jack with footplate
- ST215/75R17.5 tubeless tires – 16 ply

WEIGHTS & DIMENSIONS

Skid mounted

- Dry weight: 12750 lbs (5783 kg)
- Operating weight: 17124 lbs (7767 kg)
- 175 x 60 x 96 in



(4.45 x 1.52 x 2.44 m)

Trailer mounted

- Dry weight: 16000 lbs (7257 kg)
- Operating weight: 20374 lbs (9241 kg)
- 250 x 102 x 116 in (6.35 x 2.59 x 2.95 m)

WARRANTY

- Engine and generator covered under OEM warranty – consult factory for details.

MMG480 Options

VOLTAGE OUTPUT OPTIONS

- ◆ Dedicated voltage configurations
- ◆ Cam locks

SYSTEM CONTROLS OPTIONS

- ◆ Auxiliary strobe/audible indication for soft & hard alarm conditions

COOLANT OPTIONS

- ◆ 60/40 Coolant - cold weather applications

ENCLOSURE OPTIONS

- ◆ Fire extinguisher
- ◆ Interior cabinet light
- ◆ Control panel light

FUEL TANK OPTIONS

- ◆ Fuel transfer pump

TRAILER OPTIONS

- ◆ 6 pin or 7 spade electrical connectors
- ◆ Spare tire/wheel kit

HITCH OPTIONS

- ◆ Adjustable height - 3” lunette ring