

S175



S185



TURBO

Distributed By:



www.onesourcerental.com



One Tough Animal™

Distributed By:

One Source
RENTALS • SALES • SERVICE

www.onesourcerental.com



These are the machines that set the standard for design, productivity and comfort in skid-steer loaders! Bobcat S175 and S185 loaders offer a wide range of operator-friendly features and exciting value-added options.

Plenty of muscle, too. The impressive rated operating capacity and 118-inch lift height plus vertical lift path and 29.6-inch reach make the S175 and S185 ideal for truck loading.

Bobcat S175 and S185 loaders are the state-of-the-art work environment that will save you time, effort and money on every job!

SEE MORE. LIFT MORE. DO MORE.

Bobcat S175 and S185 Loaders deliver unequalled visibility, performance, comfort and value!

Profit-making performance and unsurpassed comfort...Bobcat S175 and S185 loaders have it all!

For example, the vertical-path lift-arm design means improved jobsite performance — and because of the lift arms' low profile, you get all-around visibility to the sides, front and rear corners of the machine when loading, unloading and turning in tight quarters.

You also get unsurpassed comfort in the roomy cab...easy entry and exit... innovative instrumentation and convenient controls... rear-pivot seat bar... fully-adjustable, optional suspension seat...and much, much more.
Read on!



FACTORY INSTALLED
Air Conditioning
NOW AVAILABLE

(S185 Only)



Choice of Attachments.

As with any Bobcat loader, you can count on a variety of quick-mounting Bobcat attachments for the S175 and S185. The operator can easily replace a bucket with a backhoe, pallet fork, landscape rake, sweeper, tiller, grapple and many more. Hookup is easier with the new optional Power Bob-Tach™ mounting system!

Built-In Safety.

The S175 and S185 give you the latest in safety technology — the Bobcat Interlock Control System (BICS™). BICS requires the operator to be seated in the loader with the seat bar in place and the engine running. After the operator presses the “press to operate loader” button, the hydraulic lift/tilt functions and traction drive system can be operated.

Serviceability.

Bobcat serviceability is unsurpassed. Simply open the swing-out tailgate for full access to the engine’s checks and fills, filters and battery. And unlike other brands, the lift arms need not be raised to service the machine. Shop time is spent repairing, not gaining access.

Distributed By:



www.onesourcerental.com



Exclusive Bob-Tach System.

For fast, secure attachment changes. Bob-Tach frame (A) moves into attachment flange (B) handle (C) pushes down easily, pressing wedge (D) through frame and attachment hole for solid connection. **Power Bob-Tach system available!**



Adjustment Not Needed.

The Bobcat “bow-tie” drive chain design uses pre-stressed, heavy-duty drive chains in two short continuous loops on each side. That means no periodic, time-consuming adjustments, plus long life even in the most rugged conditions.



Clean Cooling.

The exclusive Bobcat dual path cooling system brings clean, cool air from above, through the engine and hydraulic oil coolers, mixes it with engine compartment air, then exhausts it out two side vents.

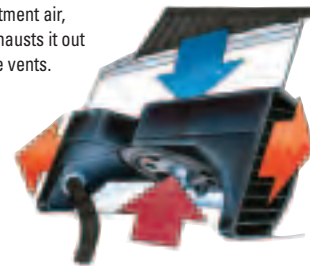

Bearing Grease? Forget It!



The industry standard of design, productivity and comfort!

Bobcat S175 and S185 loaders deliver a wide range of innovative, operator-friendly features and exciting value-added options.



Left Side Instrument Panel



Right Side Standard Instrument Panel



Optional Deluxe Instrument Panel

State-of-the-art instrument panels provide dozens of operational features, diagnostics and monitoring. Optional deluxe instrument panel includes keyless start security system, feature lockouts, digital time and job clocks, multi-language display, even a "help" menu.



More Operator Comfort

The optional, fully-adjustable suspension seat allows comfortable all-day operation. The innovative seat bar pivots from the rear, providing secondary restraint protection and serving as a comfortable armrest for operators of all sizes.



Climate-Controlled Cab

High-visibility front door — with 49% more glass — includes wiper and washer. The cab enclosure, with top, rear and side windows, will completely seal the cab for efficient use of heater or air conditioning option.



Engine and Hydraulic Systems Monitor with Shutdown

A standard feature on most Bobcat loaders, excavators and utility work machines, this system monitors vital machine functions, such as engine coolant temperature, engine oil pressure and hydraulic oil temperature. If a monitored function is out of normal operating range, the system provides an audible alert, a warning message or code and, depending on the severity of the function, may shut down the machine to avoid catastrophic failure.

Distributed By:



www.onesourcerental.com

S175	S185				S175 S185	
1,750/1,850 <small>lb.</small>	118.2 <small>in.</small>	29.6 <small>in.</small>	7.3 <small>mph</small>	46/56 <small>hp</small>	16.9/26.4 <small>gpm</small>	
Rated Operating Capacity	Lift Height	Reach	Travel Speed	Liquid-Cooled Diesel Engine	Auxiliary Flow/High-Flow	

Distributed By:



Bobcat engineering sets the standard for comfort, visibility and performance!

Greater Comfort

- The S175 and S185 cabs are operator-friendly, designed for maximum comfort and functionality.
- With their larger cab opening, both loaders are easy to enter and exit.
- The innovative seat bar pivots from the rear, providing secondary restraint protection and serving as a comfortable armrest for operators of all sizes.
- High-output halogen headlamps double the amount of illumination to the work area for better operation in low light.
- The S175 and S185 also feature a new, easy-to-read, highly functional instrument panel, along with a number of value-added options.
- Air conditioning is available in the S185's fully climate-controlled cab.

More Options

- Factory- or field-installed deluxe instrument panel includes keyless start, feature lockouts, attachment operation help screens, monitoring and diagnostic functions.
- High-flow auxiliary hydraulics operate attachments such as planers and stump grinders.
- Fully-adjustable suspension seat for all-day operator comfort.
- Cab heat and air conditioning. (A/C available on S185 only)
- Power Bob-Tach™ mounting system.

Added Value

Couple all the work-saving features of the model S175 and S185 with proven power and smooth ride, and you have skid-steer loaders that deliver optimum performance on every jobsite!

se?

Self-lubricating axle bearings never need greasing. The unique hub design offers great seal protection.

Belt Drive Advantage.

The Bobcat belt drive advantage means Bobcat loader engines can be run slower, resulting in a quieter machine that lasts longer and uses less fuel. This system also maximizes pump efficiency and minimizes steering lever effort.



Ask about the 3-year belt warranty!

Training Resources.

Training kits, available through your Bobcat dealer's parts department, let you train current and new operators and service technicians on the latest safety operation and servicing functions on Bobcat skid-steer loaders. A Spanish language version is also available.

Check the Bobcat website for more information: www.bobcat.com



S175

SKID-STEER LOADER

S185

TURBO

SKID-STEER LOADER

Worldwide Support.

With Bobcat models S175 and S185 you get more than exceptional skid-steer loaders. You also get the support of a worldwide network of Bobcat dealers offering industry-leading attachments, accessories and parts availability. Their factory-trained service technicians are equipped to handle all your parts and service requirements, including engine and hydrostatic/hydraulic components. There's an excellent warranty program, too. Get all the details from your Bobcat dealer.

Bobcat® S175 and S185 Turbo Skid-Steer Loader

Specifications

Performance

Rated Operating Capacity¹
 ROC with Optional Counterweight
 Tipping Load
 Hydraulic Pump Capacity
 High Flow Option
 Travel Speed
 Operating Weight

S175

1750 lb. (794 kg)
 1850 lb. (839 kg)
 3900 lb. (1769 kg)
 16.9 GPM (63 L/min.)
 26.4 GPM (102 L/min.)
 7.3 MPH (11.3 km/hr.)
 5808 lb. (2635 kg)

S185 Turbo

1850 lb. (839 kg)
 1950 lb. (885 kg)
 3900 lb. (1769 kg)
 16.9 GPM (63 L/min.)
 26.4 GPM (102 L/min.)
 7.3 MPH (11.3 km/hr.)
 5808 lb. (2635 kg)

Dimensions

Length (with bucket)
 Width (with bucket)
 Height
 Height to Bucket Pin

130.3 in. (3309 mm)
 68.0 in. (1727 mm)
 76.3 in. (1938 mm)
 118.2 in. (3002 mm)

Engine

Make/Model
 Fuel/Cooling
 Cylinders
 SAE NET HP/Displacement
 Fuel Tank Capacity

Kubota/V2203M-DI
 Diesel/Liquid
 4
 46/134 in.³ (2.2 L)
 23 gal. (87.1 L)

Operation

Steering and Drive
 Hydraulics
 Transmission

Forward, reverse, travel speed and steering controlled by two hand levers.
 Raise/lower lift arms and dump/rollback bucket controlled by two foot pedals or optional hand controls.
 Hydrostatic, four-wheel drive.

Standard Features

Adjustable Cushion Seat
 Automatically Activated
 Glow Plugs
 Bobcat Interlock Control System (BICS™)
 Bob-Tach
 Deluxe Cab
 Dual Path Cooling System
 Engine/Hydraulic Shutdown
 Front Auxiliary Hydraulics
 Front & Rear Lights

Lift Arm Support
 Gauges/Warning Lights
 Operator Cab
 Parking Brake
 Seat Bar (available for all Bobcat loaders)
 Seat Belt
 Spark Arrestor Muffler (S175 only)
 10-16.5 Bobcat Standard Duty Tires
 Turbo-Charger (S185 only) (Approved Spark Arrestor)

Options/Accessories

Advanced Control System (ACS)
 Air Conditioning (S185 only)
 Alarm Package (backup alarm and horn)
 Attachment Control Kit
 Bobcat Heavy Duty Tires
 Heavy Duty Offset
 Bobcat Poly-Fill Tires
 Bobcat Severe Duty Tires
 Bobcat Super Float Tires
 Cab Enclosure
 Cab Heater
 Catalytic Purifier
 Counterweight
 Deluxe Instrument Panel
 Flasher/Strobe/Rotating Beacon Lights

Gold Package Option
 High Flow Auxiliary Hydraulics Package
 Hydraulic Bucket Positioning²
 Keyless Start System
 Power Bob-Tach
 Radio Kit
 Rear Auxiliary Hydraulics
 Service Safety/Training Kit
 Side Windows
 Skid-Steer Loader Operator Training Kit
 Sound Cab
 Special Applications Kit³
 Suspension Seat (vinyl or cloth cover)

Distributed By:



www.onesourcerental.com

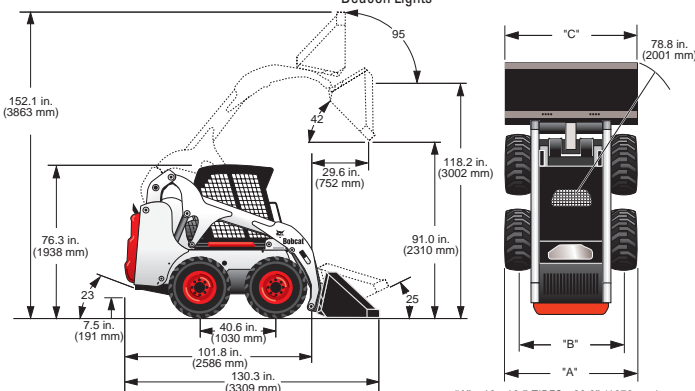

"A" 10 - 16.5 TIRES - 66.0" (1676 mm) or 60.0" (1524 mm)
 31.5 x 13 - 16.5 TIRES - 66.0" (1676 mm)
 "B" 10 - 16.5 TIRES - 54.5" (1385 mm) or 48.5" (1232 mm)
 31.5 x 13 - 16.5 TIRES - 52.3" (1328 mm)
 "C" 62 in. BUCKET WIDTH - 62.0" (1575 mm)
 68 in. BUCKET WIDTH - 68.0" (1727 mm)
 74 in. BUCKET WIDTH - 74.0" (1880 mm)

Bobcat S175 and S185 skid-steer loaders...greater performance, visibility, comfort and value!

Greater Performance

Vertical-path lift arms deliver added performance on every jobsite:

- More lift capacity.
- More lift height and reach for truck loading.
- More auxiliary hydraulic flow for better attachment operation.

Greater Visibility

The low-profile, vertical-path lift arm design and innovative cab enhance the operator's view to key areas during operation: the sides, front and rear corners of the loader.

Even with the optional front door, the S175 and S185 offer good visibility. As any operator will tell you, a better view of the work area means greater efficiency.

Greater Comfort

The cab is designed with the operator in mind, for optimum comfort and functionality. And with its larger opening and dual-tilt cylinder lift arm design, it's easy to enter and exit.

The seat bar pivots from the rear, providing secondary restraint protection; it's also a comfortable armrest for operators of all sizes. Plus, the worklight design doubles the amount of illumination to the work area for better operation in low-light areas.

Greater Options

- Factory- or field-installed, easy-to-read deluxe instrument panel.
- High-flow auxiliary hydraulics to operate attachments requiring high hydraulic horsepower, such as planers and stump grinders.
- Full suspension seat for all-day operator comfort.

Greater Value

Couple these features with proven power, smooth ride and vertical lift path capabilities and you've got skid-steer loaders that deliver top performance, no matter what the job. Get in the seat of a S175 or S185 today for a great view and an even greater value!

S175

1750 LB.
 Rated Operating Capacity
118.2 IN.
 Lift Height
46 HP
 Liquid-Cooled Diesel Engine

S185 Turbo

1850 LB.
 Rated Operating Capacity
118.2 IN.
 Lift Height
56 HP
 Turbo-Charged, Liquid-Cooled Diesel Engine

Optional Deluxe Instrument Package includes:

- Multi-language capability
- System diagnostic capability
- All gauges read in metric or English units
- Feature lockouts
- Keyless start security
- Digital and job clocks
- Help screens
- Attachment information

NOTE - Where applicable, dimensions are in accordance with Society of Automotive Engineers (SAE) and ISO standards. Specifications and design are subject to change without notice. Pictures of Bobcat loaders may show other than standard equipment. All dimensions are given for loader equipped with standard tires. All dimensions are shown in inches. Respective metric dimensions are enclosed by parentheses. Bobcat Company complies with the requirements of ISO 9001 as registered with BSI.

¹ Operating capacity rated with standard digging bucket according to SAE standard J818 - OPERATING CAPACITY TO EQUAL NO MORE THAN ONE HALF THE TIP LOAD.

² Bucket positioning helps operator keep the same tilt of the load during lifting.

³ Includes Lexan front door, top and rear windows.

⁴ Special application kit (see #3) must be used.

Bobcat Attachments for these models:

Angle Broom*
 Auger
 Backhoe
 Box Blade
 Brushcat
 Rotary Cutter
 Buckets
 Chipper*
 Combination Bucket
 Concrete Mixer*
 Concrete Pump*
 Digger
 Drozer Blade*
 Drop Hammer
 Dumping Hopper
 Ejector Bucket
 Farm Grapple (for use with utility fork or bucket)

Front Scarifier
 Grader*
 Hydraulic Breaker⁴
 Hydraulic Pallet Fork
 Industrial Grapple
 Landplane
 Landscape Rake
 Mower
 Packer Wheel
 Pallet Fork
 Planer*
 Rear Stabilizer
 Root Rake
 Scarifier
 Scraper
 Seeder
 Snow Blade
 Snowblower*
 Sod Layer*
 Soil Conditioner*
 Spreader
 Stump Grinder*
 Sweeper
 Three-Point Hitch
 Tiller
 Tilt-Tatch
 Tracks
 Tree Spade*
 Trench Compactor
 Trencher
 Utility Fork
 Vibratory Roller
 Water Kit
 Wheel Saw
 Whisker
 Push Broom

* Attachment Control Kit Required.



B-1749

Bobcat Company
 P.O. Box 6000 • West Fargo, ND 58078
 www.bobcat.com

Printed in U.S.A.

An **IR** Ingersoll-Rand business

Kn-30M-305-#B6338105-F